

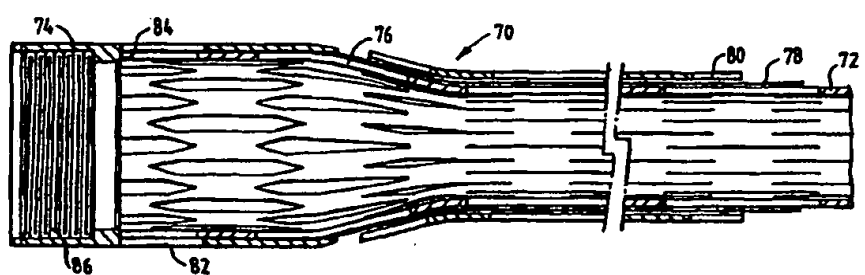

INTERNATIONAL APPLICATION PUBLISHED UNDER THE PATENT COOPERATION TREATY (PCT)

<p>(51) International Patent Classification ⁶ : E21B 43/10</p>	<p>A1</p>	<p>(11) International Publication Number: WO 99/23354 (43) International Publication Date: 14 May 1999 (14.05.99)</p>
<p>(21) International Application Number: PCT/GB98/03261 (22) International Filing Date: 2 November 1998 (02.11.98) (30) Priority Data: 9723031.2 1 November 1997 (01.11.97) GB (71) Applicant (for all designated States except US): PETROLINE WELLSYSTEMS LIMITED [GB/GB]; Offshore Technology Park, Claymore Drive, Bridge of Don, Aberdeen AB23 8GD (GB). (72) Inventor; and (75) Inventor/Applicant (for US only): METCALFE, Paul, David [GB/GB]; North Wing, Bucklerburn Steading, Peterculter AB14 0NP (GB). (74) Agents: McCALLUM, William, Potter et al.; Cruikshank & Fairweather, 19 Royal Exchange Square, Glasgow G1 3AE (GB).</p>	<p>(81) Designated States: AL, AM, AT, AU, AZ, BA, BB, BG, BR, BY, CA, CH, CN, CU, CZ, DE, DK, EE, ES, FI, GB, GD, GE, GH, GM, HR, HU, ID, IL, IS, JP, KE, KG, KP, KR, KZ, LC, LK, LR, LS, LT, LU, LV, MD, MG, MK, MN, MW, MX, NO, NZ, PL, PT, RO, RU, SD, SE, SG, SI, SK, SL, TJ, TM, TR, TT, UA, UG, US, UZ, VN, YU, ZW, ARIPO patent (GH, GM, KE, LS, MW, SD, SZ, UG, ZW), Eurasian patent (AM, AZ, BY, KG, KZ, MD, RU, TJ, TM), European patent (AT, BE, CH, CY, DE, DK, ES, FI, FR, GB, GR, IE, IT, LU, MC, NL, PT, SE), OAPI patent (BF, BJ, CF, CG, CI, CM, GA, GN, GW, ML, MR, NE, SN, TD, TG). Published With international search report.</p>	

(54) Title: EXPANDABLE DOWNHOLE TUBING



(57) Abstract
A tubing coupling method comprises the steps: providing a length of expandable tubing (72) and a length of larger diameter non-expanding tubing (74); connecting an end portion of the expandable tubing (72) to an end portion of the non-expanding tubing (74) with a portion of expandable tubing (76); running the tubing (72, 74, 76) into a bore; and expanding the expandable tubing (72, 76). The expandable tubing (72) may form part of an expandable well or sand screen, or may be expandable bore liner (12).

FOR THE PURPOSES OF INFORMATION ONLY

Codes used to identify States party to the PCT on the front pages of pamphlets publishing international applications under the PCT.

AL	Albania	ES	Spain	LS	Lesotho	SI	Slovenia
AM	Armenia	FI	Finland	LT	Lithuania	SK	Slovakia
AT	Austria	FR	France	LU	Luxembourg	SN	Senegal
AU	Australia	GA	Gabon	LV	Latvia	SZ	Swaziland
AZ	Azerbaijan	GB	United Kingdom	MC	Mosaco	TD	Chad
BA	Bosnia and Herzegovina	GE	Georgia	MD	Republic of Moldova	TG	Togo
BB	Barbados	GH	Ghana	MG	Madagascar	TJ	Tajikistan
BE	Belgium	GN	Guinea	MK	The former Yugoslav Republic of Macedonia	TM	Turkmenistan
BF	Burkina Faso	GR	Greece	ML	Mali	TR	Turkey
BG	Bulgaria	HU	Hungary	MN	Mongolia	TT	Trinidad and Tobago
BJ	Benin	IE	Ireland	MR	Mauritania	UA	Ukraine
BN	Brazil	IL	Israel	MW	Malawi	UG	Uganda
BY	Belarus	IS	Iceland	MX	Mexico	US	United States of America
CA	Canada	IT	Italy	NE	Niger	UZ	Uzbekistan
CF	Central African Republic	JP	Japan	NL	Netherlands	VN	Viet Nam
CC	Congo	KE	Kenya	NO	Norway	YU	Yugoslavia
CH	Switzerland	KG	Kyrgyzstan	NZ	New Zealand	ZW	Zimbabwe
CI	Côte d'Ivoire	KP	Democratic People's Republic of Korea	PL	Poland		
CM	Cameroon	KR	Republic of Korea	PT	Portugal		
CN	China	KZ	Kazakhstan	RO	Romania		
CU	Cuba	LC	Saint Lucia	RU	Russian Federation		
CZ	Czech Republic	LI	Liechtenstein	SD	Sudan		
DE	Germany	LK	Sri Lanka	SE	Sweden		
DK	Denmark	LR	Liberia	SG	Singapore		
EE	Estonia						

EXPANDABLE DOWNHOLE TUBING

This invention relates to expandable downhole tubing. In particular, the invention relates to coupling or connecting expandable downhole tubing. One aspect of the invention relates to a method of locating a section of expandable tubing in a bore.

Expandable tubing for use in downhole applications is described in WO93/25800, the disclosure of which is incorporated herein by reference. The tubing is useful as, for example, borehole liner or as a sandscreen support, the use of expandable tubing in sandscreens being more fully described in WO97/17524, the disclosure of which is also incorporated herein by reference. In one application, a section of expandable tubing is positioned in an unlined section of bore intersecting a hydrocarbon-bearing formation, below an existing bore casing and bore liner. The tubing is then expanded, preferably into contact with the bore wall. The expanded liner supports the bore wall while allowing oil and gas to pass from the formation into the bore. In another application, an expandable well screen is provided, the screen comprising perforated filter sheets mounted on an expandable slotted carrier tube and within a coaxial expandable slotted protective tube. The well screen is expanded downhole to such a size that the protective tube can be set against the surrounding formation.

For locating expandable tubing in a bore it would be preferable to provide a secure connection between the upper end of the expandable tubing and the lower end of an existing bore liner; simply locating the tubing in the
5 liner, with no mechanical connection therebetween, may result in an offset between the two, creating an irregularity on which tools may snag and an unwanted gap through which fluid may flow.

US Patent No. 3,353,599 discloses a method for
10 securing ends of expandable liner to solid surrounding tubing by means of plastic impregnated glass filter mats. However, the applicant considers that this method would encounter many difficulties in this particular application due to, for example, contamination of the mats by the fluid
15 in the bore and the possibility of the mats being dislodged or damaged during installation of the liner and the expandable tubing, or during other downhole operations.

It is among the objectives of the present invention to obviate or mitigate these disadvantages.

20 According to the present invention there is provided a method of coupling a section of expandable tubing, the method comprising the steps:

- providing a length of expandable tubing and a length of larger diameter non-expanding tubing;
- 25 connecting an end portion of said expandable tubing to an end portion of said non-expanding tubing with a portion of expandable tubing;
- running the tubing into a bore; and

expanding the expandable tubing.

According to a further aspect of the present invention there is provided a tubing assembly comprising a length of expandable tubing, a length of larger diameter non-expanding tubing, and a connecting portion of expandable tubing connecting an end portion of the expandable tubing to an end portion of the non-expanding tubing.

These aspects of the invention facilitate connection of a length of expandable tubing to a length of non-expanding tubing.

The expandable tubing may be a borehole liner or support, or may form part of an expandable well screen or sand screen.

The non-expanding tubing may be a solid connector or coupling, and thus may be a solid connector for joining two lengths of expandable tubing. In particular, this embodiment of the invention permits expandable well screen or sand screen sections to be connected using solid connectors, obviating the difficulties involved in connecting such well screen sections utilising expandable connectors.

The connecting portion may be formed by partially expanding an end of the expandable tubing to a diameter corresponding to the non-expanding tubing. Alternatively, the non-expanding tubing may have an expandable tapering end portion which forms the connecting portion, the smaller diameter end of the tapering portion being of a diameter corresponding to the expandable tubing.

The connecting portion may be welded to one or both of the expandable tubing and the non-expanding tubing. Alternatively, the connection may be provided by other means, such as screw threads, pins, screws, rivets or
5 radially movable keys or fingers engaging corresponding profiles.

According to another aspect of the present invention there is provided a method of locating a section of expandable tubing in a bore, the method comprising the
10 steps:

providing a length of expandable tubing and a length of larger diameter non-expanding tubing;

connecting an end portion of said expandable tubing to an end portion of said non-expanding tubing with a portion
15 of expandable tubing;

running the connected tubing into a bore;

fixing said non-expanding tubing in the bore; and
expanding the expandable tubing.

According to a still further aspect of the present
20 invention there is provided a tubing assembly comprising a length of expandable tubing, a length of larger diameter non-expanding tubing including means for connecting the non-expanding tubing to further tubing located in a bore, and a connecting portion of expandable tubing connecting an
25 end portion of the expandable tubing to an end portion of the non-expanding tubing, the arrangement being such that, in use, the connected tubing may be run into a bore as a unit.

Thus, in these aspects of the present invention, the expandable tubing is connected to the non-expanding tubing on surface, prior to running the expandable tubing into the bore and prior to expansion of the tubing. The non-expanding tubing may be fixed in the bore by any suitable connecting means, typically by connection to an existing section of bore liner or casing. The connection may utilise, for example, a liner hanger, a packer, cooperating screw threads or radially movable keys engaging corresponding profiles.

The expandable tubing may be a borehole liner or support, or may form part of an expandable well screen or sand screen.

The connecting portion may be formed by expanding an upper end of the expandable tubing to a diameter corresponding to the non-expanding tubing. Alternatively, the non-expanding tubing may have an expandable tapering lower end portion which forms the connecting portion, the smaller diameter end of the tapering portion being of a diameter corresponding to the expandable tubing.

Preferably also, the assembly includes a running tool including means for releasably mounting the tubing thereon. The mounting means may be released utilising one of, or a combination of, mechanical force and fluid pressure. Preferably also, the running tool incorporates means for expanding the expandable tubing, which means may be a cone or mandrel which will expand the tubing when pushed or pulled therethrough. Most preferably, the expanding means

is initially located within the connecting portion.

The connecting portion may be welded to one or both of the expandable tubing and the non-expanding tubing. Alternatively, the connection may be provided by other
5 means, such as screw threads, pins, screws, rivets or radially movable keys or fingers engaging corresponding profiles.

These and other aspects of the present invention will now be described, by way of example, with reference to the
10 accompanying drawings, in which:

Figure 1 is a sectional view of a tubing assembly in accordance with an embodiment of the present invention, shown located in the sump end of a bore;

Figure 2 is an enlarged sectional view of a portion of
15 the tubing assembly of Figure 1;

Figure 3 is a sectional view of a portion of a tubing assembly in accordance with a further embodiment of the present invention;

Figure 4 is a sectional view of a portion of a tubing
20 assembly in accordance with another embodiment of the present invention; and

Figure 5 is a sectional view of a portion of a tubing assembly in accordance with a still further embodiment of the present invention.

25 The assembly 10 comprises expandable tubing 12 connected to the lower end of a non-expanding sleeve 14, the sleeve 14 being fixed relative to a section of bore casing 15 which defines a seal bore 16. The expandable

tubing 12 is initially of a smaller diameter than the sleeve 14 and casing 15 and extends into the uncased lower end of a drilled bore 18, this being the section of the bore 18 which intersects the oil-bearing formation. The expandable tubing 12 is similar to that described in WO93/25800, the tubing wall defining a multiplicity of overlapping longitudinal slots 20. A number of tubing sections 12a, 12b are provided and are joined together using appropriate connectors 22, such as the connectors described in PCT/GB96/01250 or PCT/GB96/03026, the disclosures of which are incorporated herein by reference.

At its upper end 12c, the tubing 12 has been pre-expanded to a diameter corresponding to the diameter of the sleeve 14, and the pre-expanded portion 12c welded to the sleeve 14, as illustrated in greater detail in Figure 2. The lower end portion of the sleeve 14 receives the upper pre-expanded end 12c of the tubing and is slotted 40, to facilitate welding of the tubing 12c to the sleeve 14. Further, the sleeve 14 defines a shoulder 42 for abutting the upper end of the expanded tubing end 12c. In use, the sleeve 14 is threaded and pinned to a liner section including a conventional hanger (not shown) for connection to the existing bore casing 15.

Located within the pre-expanded portion 12c is a running tool 24 for connection to the lower end of a running string (not shown), typically formed of drill pipe. The running tool 24 features radially movable keys 26 which releasably engage a profile 28 on the expandable tubing 12.

The illustrated running tool is similar to the tool described in our earlier UK patent application GB 9625937.9, the disclosure of which is incorporated herein by reference, and may be activated by fluid pressure to retract the keys 26 and release the tubing assembly 12, 14 when desired. The upper end of the running tool 24 includes an expansion cone 30 which may be pushed downwardly to expand the tubing 12, as will be described below.

In use, the expandable tubing 12 and the sleeve 14 are welded together on the surface and the running tool 24 located within the tubing assembly 12, 14 with the keys 26 extended to engage the tubing profile 28. The running tool 24 is then mounted on the lower end of the running string and the assembly of the tubing 12, sleeve 14, liner, liner hanger and tool 24 run into the bore 18.

On reaching the lower end of the bore 18, the liner hanger is actuated to fix the liner to the lower end of the bore casing, above the uncased section of bore. The running tool 24 is then manipulated and fluid pressure applied to the tool 24 from the surface through the running string to retract the keys 26 and release the tubing 12 and liner. The running tool 24 is then pushed downwardly, through the tubing 12, such that the cone 30 expands the tubing 12 into contact with the bore wall, the solid non-expanding sleeve 14 preventing the pre-expanded tubing end 12c from ballooning out during expansion of the remainder of the tubing 12. The running tool 24 is then withdrawn.

Thus, the invention obviates the need to form a connection between the expandable tubing 12 and the non-expanding liner while the tubing 12 and liner are downhole.

Reference is now made to Figure 3 of the drawings, which is a sectional view of a portion of a tubing assembly 48 in accordance with a further embodiment of the present invention. In this embodiment a lower liner section 50 defines a tapering connecting portion 52 formed of a plurality of connecting arms 54. The upper end of the expandable tubing 56 is fixed to the arms 54 by appropriate screws 58, and it will be noted that the slots 60 in the connecting portion 52 correspond with the slots 62 in the expandable tubing 56.

This assembly 48 is utilised in a similar manner to the assembly 10 described above, however the expansion cone 30 will expand the tapering connection portion 52 as well as the expandable tubing 56.

Reference is now made to Figure 4 of the drawings, which illustrates a tubing assembly 70 comprising a length of expandable tubing, in the form of an expandable slotted carrier tube 72, a length of larger diameter non-expanding tubing, in the form of a solid connector 74, and a connecting portion of expandable tubing 76 connecting the end portion of the carrier tube 72 to the end portion of the connector 74.

The carrier tube 72 supports perforated filter sheets 78 and an expandable slotted protective tube 80 is mounted over the sheets 78, thus forming an expandable sand screen.

assembly, such as described in WO97/17524.

At its upper end, the carrier tube 72 has been pre-expanded to a diameter corresponding to the diameter of the connector 74, and the pre-expanded connecting portion 76 welded to the connector 74. The lower end portion of the connector 74 receives the connecting portion 76 and is slotted 82, to facilitate welding of the tubing portion 76 to the connector 74. Further, the connector 74 defines a shoulder 84 for abutting the upper end of the expanded tubing end 76, and an internal thread 86.

The perforated filter sheets 78 extend to adjacent the end of the carrier tube 72 and thus extend into the connector 74. The outer protective tube 80 stops short of the end of the carrier tube 72 and does not extend into the connector 74. The pre-expansion of the carrier tube 72 produces a corresponding expansion of the filter sheets 78 and an expansion of the end of the tube 80.

In use, the connector 74 is threaded and pinned to a corresponding solid connector (not shown) defining an external thread coupled to the lower end of another expandable sand screen section. A number of sand screen sections may be coupled in this manner and run downhole to a desired location in the bore. An expansion cone or the like is then pushed or pulled through the sand screen sections and causes the unexpanded and partially expanded sections of sand screen to expand to a diameter corresponding to the diameter of the connectors 74, which will correspond closely to the bore diameter. Further, as

described in WO93/25800, by selecting an appropriate cone profile it is possible to expand the tubing to a diameter greater than that of the cone, and in this manner it may be possible to expand the sand screen assembly such that the
5 outer tubing 80 is expanded into contact with the bore wall. This effect may also be achieved or facilitated by selecting the relative dimensions of the connector 74 and sand screen elements such that on expanding the inner tubing 72 to a diameter corresponding to the inner diameter
10 of the connector 74, the outer surface of the expanded tubing 80 extends radially beyond the outer surface of the connector.

Reference is now made to Figure 5 of the drawings, which illustrates a tubing assembly 90 in accordance with
15 a still further aspect of the present invention. The assembly 90 comprises an expandable pin connector 92, for coupling to a section of expandable bore liner or an expandable screen, a solid crossover section 94 for coupling to a hanger, and a tapering connecting portion 96
20 machined in a similar manner to a section of expandable tubing, that is the portion 96 defines a number of overlapping longitudinal slots 98.

The pin connector 92 defines an external thread 100, and an undercut 102 for engaging corresponding features on
25 a connector provided on the expandable bore liner or screen; the expandable connector is generally similar in form to the connector described in our PCT/GB96/01250, the disclosure of which is incorporated herein by reference.

It will be clear to those of skill in the art that the above described embodiments are merely exemplary of the present invention and that various modifications and improvements may be made thereto without departing from the scope of the invention. For example, the assembly 10 may be provided in conjunction with another form of running tool, or may be utilised to locate expandable tubing in other locations in a bore and to connect expandable tubing to other forms of solid tubing. Further, the connector 74 may be utilised to connect other forms of sand screen incorporating different filter media, or may be utilised to connect single lengths of expandable tubing.

CLAIMS

1. A tubing coupling method comprising the steps:
providing a length of expandable tubing and a length
of larger diameter non-expanding tubing;
5 connecting an end portion of said expandable tubing to
an end portion of said non-expanding tubing with a portion
of expandable tubing;
running the tubing into a bore; and
expanding the expandable tubing.
- 10 2. The method of claim 1, wherein the expandable tubing
is expanded to provide a borehole liner or support.
3. The method of claim 1, wherein the expandable tubing
is expanded to provide at least part of an expandable well
screen or sand screen.
- 15 4. The method of any of claims 1, 2 or 3, wherein the
non-expanding tubing is a solid connector and is joined to
a second length of expandable tubing.
- 20 5. The method of any of claims 1 to 4, wherein the
connecting portion of expandable tubing is formed by
partially expanding an end of the expandable tubing to a
diameter corresponding to the non-expanding tubing.

6. The method of any of claims 1 to 4, wherein the connecting portion of expandable tubing is formed by providing the non-expanding tubing with an expandable tapering end portion.
- 5 7. The method of any of the preceding claims, wherein the connecting portion is welded to one or both of the expandable tubing and the non-expanding tubing.
8. The method of any of claims 1 to 6, wherein the connecting portion is coupled to one or both of the expandable tubing and the non-expanding tubing by
10 mechanical fasteners.
9. A tubing assembly comprising a length of expandable tubing, a length of larger diameter non-expanding tubing, and a connecting portion of expandable tubing connecting an end portion of the expandable tubing to an end portion of the non-expanding tubing.
15
10. The assembly of claim 9, wherein the expandable tubing is expandable to form a borehole liner or support.
11. The assembly of claim 10, wherein the expandable tubing is or forms part of an expandable well screen or sand screen.
20
12. The assembly of claim 9, 10 or 11, wherein the non-

expanding tubing is or forms part of a connector.

13. The assembly of claim 12, wherein the connector is adapted for joining two lengths of expandable tubing.

5 14. The assembly of claim 13, wherein the connector is adapted for joining lengths of expandable tubing forming part of respective expandable well screen or sand screen sections.

10 15. The assembly of any of claims 9 to 14, wherein the connecting portion is a partially expanded end portion of the expandable tubing.

16. The assembly of any of claims 9 to 14, wherein the connecting portion is an expandable tapering end portion of the non-expanding tubing.

15 17. The assembly of claim 9, wherein the expandable tubing is an expandable connector.

18. A method of locating a section of expandable tubing in a bore, the method comprising the steps:

providing a length of expandable tubing and a length of larger diameter non-expanding tubing;

20 connecting an end portion of said expandable tubing to an end portion of said non-expanding tubing with a portion of expandable tubing;

running the connected tubing into a bore;
fixing said non-expanding tubing in the bore; and
expanding the expandable tubing.

5 19. The method of claim 18, further comprising fixing the
non-expanding tubing in the bore by connection to an
existing section of bore liner or casing.

20. The method of claim 19, wherein the non-expanding
tubing is fixed in the bore by a liner hanger.

10 21. A tubing assembly comprising a length of expandable
tubing, a length of larger diameter non-expanding tubing
including means for connecting the non-expanding tubing to
further tubing located in a bore, and a connecting portion
of expandable tubing connecting an end portion of the
expandable tubing to an end portion of the non-expanding
15 tubing, the arrangement being such that, in use, the
connected tubing may be run into a bore as a unit.

22. The assembly of claim 21, further comprising a running
tool including means for releasably mounting the tubing
thereon.

20 23. The assembly of claim 22, wherein the mounting means
is releasable by one of, or a combination of, mechanical
force and fluid pressure.

24. The assembly of claims 22 or 23, wherein the running tool incorporates means for expanding the expandable tubing.

25. The assembly of claim 24, wherein the expanding means
5 is initially located within the connecting portion.

1/3

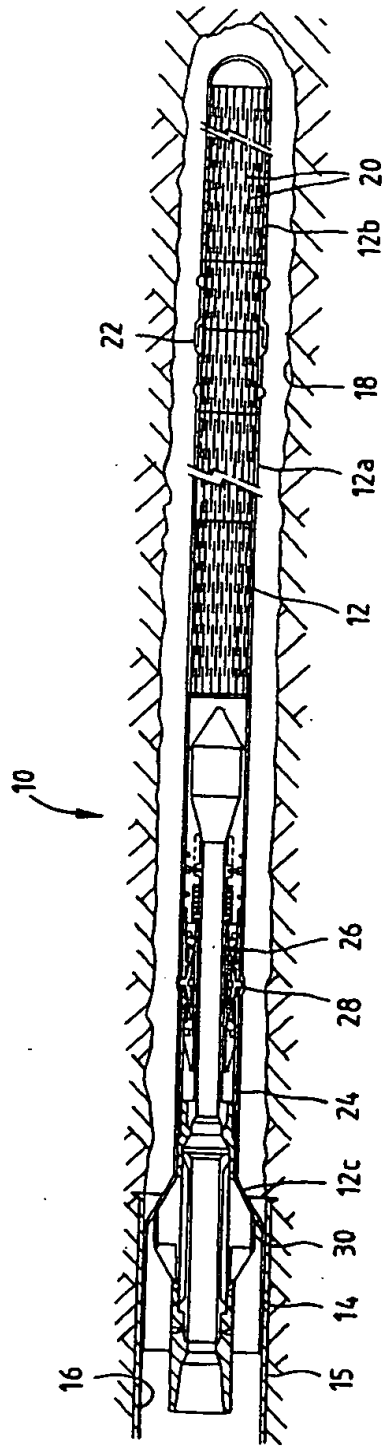

Fig. 1

SUBSTITUTE SHEET (RULE 26)

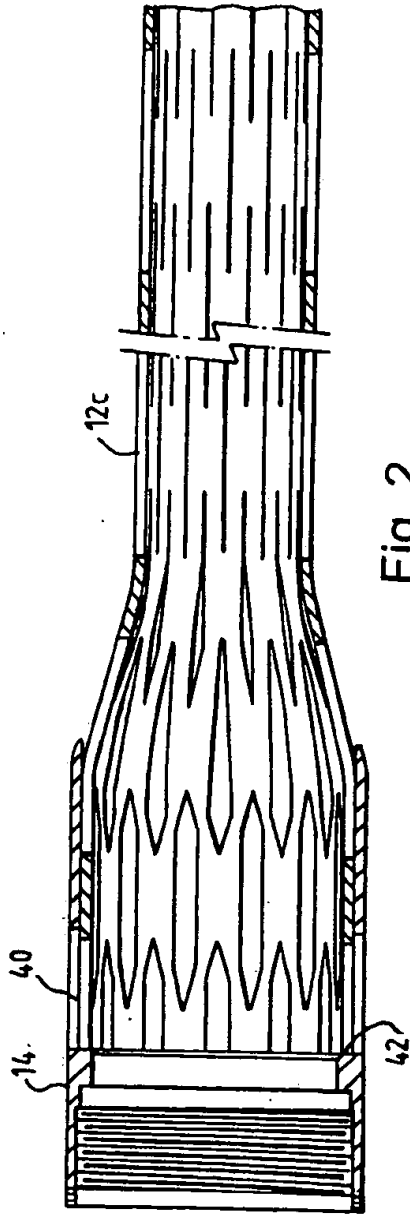

Fig. 2

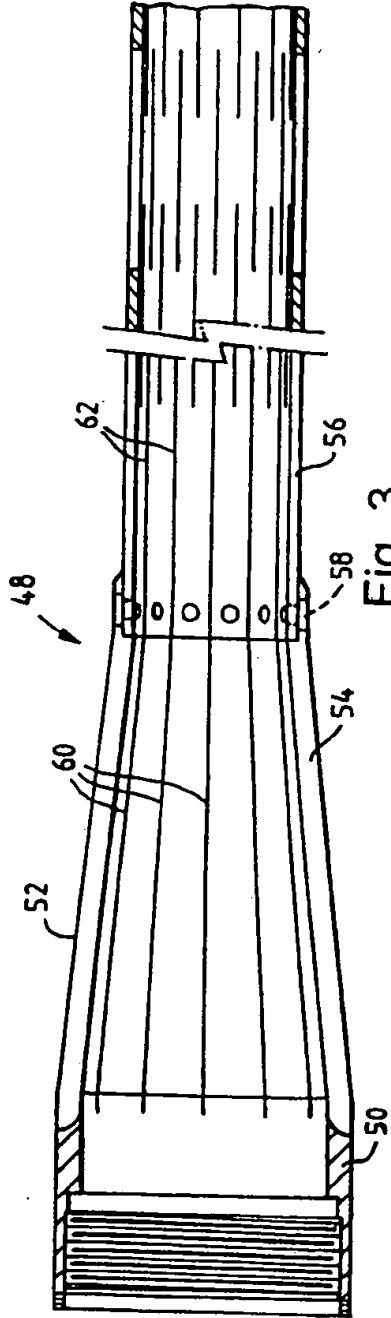

Fig. 3

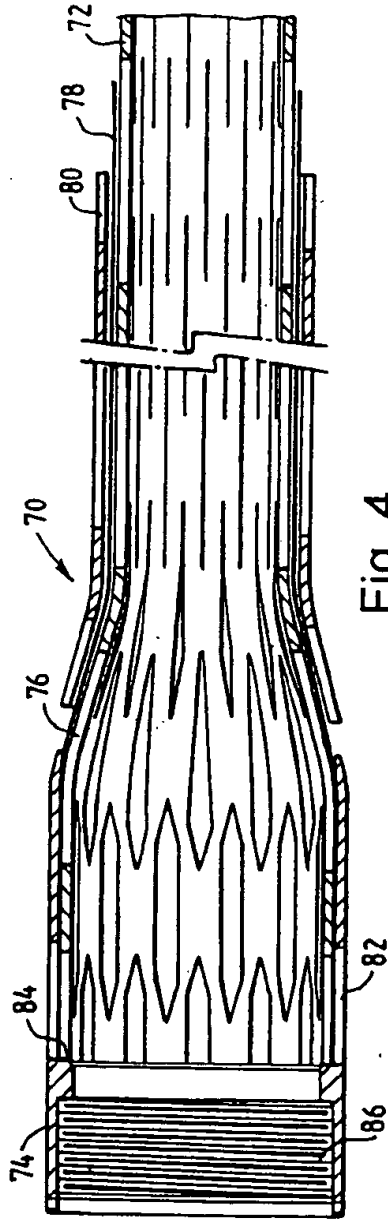

Fig. 4

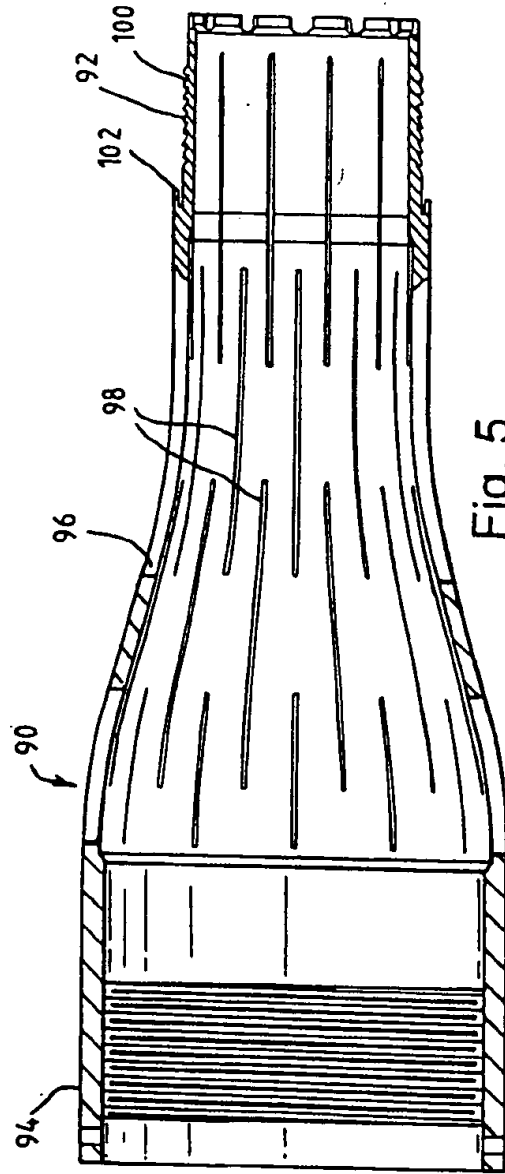

Fig. 5

INTERNATIONAL SEARCH REPORT

International Application No
PCT/GB 98/03261

A. CLASSIFICATION OF SUBJECT MATTER
IPC 6 E21B43/10

According to International Patent Classification (IPC) or to both national classification and IPC

B. FIELDS SEARCHED

Minimum documentation searched (classification system followed by classification symbols)
IPC 6 E21B F16L

Documentation searched other than minimum documentation to the extent that such documents are included in the fields searched

Electronic data base consulted during the international search (name of data base and, where practical, search terms used)

C. DOCUMENTS CONSIDERED TO BE RELEVANT

Category *	Citation of document, with indication, where appropriate, of the relevant passages	Relevant to claim No.
A	WO 93 25800 A (SHELL CANADA LTD ;SHELL INT RESEARCH (NL)) 23 December 1993 cited in the application see the whole document	1,9,18, 21
A	US 3 477 506 A (MALONE BILLY C) 11 November 1969 see figures	1,9,18, 21
P,A	WO 98 00626 A (SHELL INT RESEARCH ;SHELL CANADA LTD (CA)) 8 January 1998 see figure 1	1
P,A	US 5 785 120 A (SMALLEY MICHAEL T ET AL) 28 July 1998 see abstract	1

Further documents are listed in the continuation of box C.

Patent family members are listed in annex.

* Special categories of cited documents :

- *A* document defining the general state of the art which is not considered to be of particular relevance
- *E* earlier document but published on or after the international filing date
- *L* document which may throw doubts on priority claim(s) or which is cited to establish the publication date of another citation or other special reason (as specified)
- *O* document referring to an oral disclosure, use, exhibition or other means
- *P* document published prior to the international filing date but later than the priority date claimed

- *T* later document published after the international filing date or priority date and not in conflict with the application but cited to understand the principle or theory underlying the invention
- *X* document of particular relevance; the claimed invention cannot be considered novel or cannot be considered to involve an inventive step when the document is taken alone
- *Y* document of particular relevance; the claimed invention cannot be considered to involve an inventive step when the document is combined with one or more other such documents, such combination being obvious to a person skilled in the art.
- *A* document member of the same patent family

Date of the actual completion of the international search

15 January 1999

Date of mailing of the international search report

22/01/1999

Name and mailing address of the ISA
European Patent Office, P.B. 5018 Patentlaan 2
NL - 2280 HV Rijswijk
Tel. (+31-70) 340-2040, Tr. 31 651 epo nl.
Fax: (+31-70) 340-3016

Authorized officer

Fonseca Fernandez, H

INTERNATIONAL SEARCH REPORT

Information on patent family members

Int. l. Application No

PCT/GB 98/03261

Patent document cited in search report	A	Publication date	Patent family member(s)	Publication date
WO 9325800	A	23-12-1993	AU 672008 B AU 4324593 A CA 2137565 A DE 69305852 D DE 69305852 T DK 643795 T EP 0643795 A JP 7507611 T MD 960219 A NO 944746 A NZ 253125 A US 5366012 A	19-09-1996 04-01-1994 23-12-1993 12-12-1996 22-05-1997 14-04-1997 22-03-1995 24-08-1995 31-05-1997 03-02-1995 27-02-1996 22-11-1994
US 3477506	A	11-11-1969	NONE	
WO 9800626	A	08-01-1998	AU 3442097 A	21-01-1998
US 5785120	A	28-07-1998	AU 4955097 A WO 9821444 A	03-06-1998 22-05-1998